

MMP3

2025 Mediakit

MAGAZINE

MacPlas, the most read in Italy
mailed to 7,000 companies

WEBSITE

MacPlas Online, e-magazine
for the global plastics
and rubber industry

- News and classified ads
- Trade shows and sectoral events
- Banner ads

NEWSLETTER

MacPlas E-News, reaching
over 30,000 specialized
players worldwide,
both in Italian and
English editions

For a free subscription click on
www.macplas.it



Associated with:



In 2024 the average circulation of each issue of MacPlas was about 7,000 copies.

The technical magazine MacPlas is distributed to companies operating in different segments of the plastics and rubber industry. The circulation for each issue of the Italian edition, on the basis of readers' activity, is the following:

| | |
|---|--------------|
| Italian plastics and rubber processors and recyclers (injection moulding and related processes 52%, extrusion 31%, blow moulding 5%, thermoforming 5%, others 7%) | 5,500 |
| Manufacturers and representatives of machinery & equipment (including Amaplast Members) | 700 |
| Producers of raw materials and additives | 300 |
| Others (retailers, agents etc.) | 300 |
| Abroad (chambers of commerce, associations etc.). | 200 |
| Total average circulation | 7,000 |

MACPLAS INTERNATIONAL

Some special supplements (in local language) are scheduled concurrently with the most important specialized fairs worldwide, that often host collective participations of Italian exhibitors.



2025 ADVERTISING RATES

| SIZES (full color) | EURO (VAT excluded) |
|---|---------------------|
| Cover: 210x183 mm + 3 mm bleed on each side | 3000 |
| Full colour, bleed (210x297 mm + 3 mm oversize for each side) | 1,300 |
| 1/2 page, inside the grid (172x125 or 86x250 mm) | 850 |
| 1/3 page, inside the grid (172x90 or 62x250 mm) | 600 |
| SPECIAL POSITIONS | |
| Back cover | 2,000 |
| Page 3 | 1,900 |
| Inside front cover | 1,700 |
| Opposite contents page | 1600 |
| Within contents page | 1500 |
| Single gatefold | 2100 |
| Double gatefold | 2000 per page side |
| Facing colophon/advertisers list | 1,600 |
| Facing the "editor's letter" | 1,500 |
| Inside back cover | 1,500 |
| Requested placement (within the first 30 pages or according to the customer needs) | 1,400 |
| INSERTS | |
| 2 pages | 1,500 |
| Every 2 additional pages | 700 |
| ADVERTORIALS | |
| Full page, well highlighted (conditions to be established with the editorial staff) | 1,300 |

Different sizes are available on request

DISCOUNTS

| | |
|--------------------------|-----|
| From 2,500 to 4,000 euro | 10% |
| From 4,001 to 6,000 euro | 15% |
| Over 6,000 euro | 20% |

The quantity discounts cannot be summed up for different advertisers, even if managed by the same advertising agency.

The agency commission (15%) is reserved only for acknowledged advertising agencies and is credited to them after payment of the advertisement by the customer.

A 15% discount is granted to Amaplast and Assogomma Members, but, in this case, the agency commission is not reserved.

CLASSIFIED ADS

This specific space is available for companies or private individuals interested in trade services or business opportunities, vacant positions, materials, reconditioned or stock machinery and equipment.

The rate for each module (75x20 mm) is 50 euro + VAT.

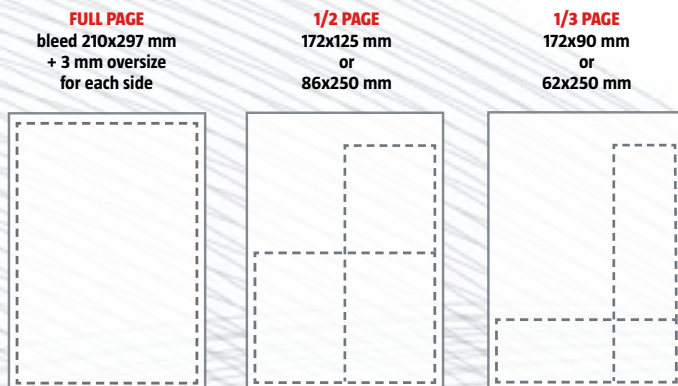

PRINTING MATERIAL

Printing material to be delivered on CD-R or transmitted by e-mail (g.zazzaro@macplas.it) within the dates mentioned in the editorial plan of page 5. The subject must be saved in CMYK, in the present sizes and formats, as high resolution (300 DPI) PDF format, with a 3-mm trim oversize in case of bleed ads. In order to avoid any possible objections, a printing proof (chromaline) for full colour ads with the CD-R is necessary. To be consistent with readers, the ads must be in the same language as the edition in which they are published (Italian, English, Russian, etc.). Exceptions must be agreed in advance with the editorial staff of MacPlas.

- **Inserts** (210x297 mm) must have trimming edge 10 mm up and 13 mm down, 2 mm left and 8 mm right. Paper weight must be between 135 and 175 g/m².
- **Sizes of flyers** must not exceed 200x275 mm.

MAILING

Our **MAILING SERVICE** (DEM) consists of sending an e-mail, completely customizable, from MacPlas account but on behalf of your company. If you are interested in using this service, you should provide a text in ZIP HTML format, including one or more links and possible images. We will tell you the number of readers who have downloaded the images and the number of readers who have clicked on links included in your communication. Mailing service for the whole mailing list has the following rates:

| | |
|--|------------|
| DEM to 20,000 Italian companies | 1,800 euro |
| DEM to 30,000 worldwide companies | 2,100 euro |
| 2 DEM to Italian and English mailing lists | 2,500 euro |

MACPLAS ONLINE (www.macplas.it) is a real daily updated magazine authorized by the court of Milan. The table below describes the various formats available to advertisers to promote their activity and the 2025 rates for the English and Italian versions of the website.



Banner files can be delivered in one of the following formats: GIF, animated GIF, JPG or Flash. Flash files must include the destination URL.

MACPLAS ONLINE

STANDARD DIGITAL FORMATS

| BANNER (MAX 100 KBYTE) | SIZE | EURO (VAT EXCL.) | LENGTH OF TIME |
|--|------------------|------------------|----------------|
| Top header (all pages) | 1,230x130 pixels | 800 € | 1 month |
| Central banner (after the first news, only on the home page) | 810x154 pixels | 600 € | 1 month |
| Side banner (below "most read news") | 390x149 pixels | 350 € | 1 month |
| Side banner (above "most read news") | 390x149 pixels | 470 € | 1 month |
| Skyscraper (all pages) | 390x600 pixels | 600 € | 1 month |

ADVERTORIAL

| | | |
|---|-------|---------|
| Written text (max 3,000 characters + 1-2 pictures (72 dpi, max width 500 pixels)) | 750 € | 15 days |
|---|-------|---------|

CLASSIFIED ADS AND JOB OFFERS

| | | |
|-------------------------------------|-------|---------|
| Written text (max 1,500 characters) | 150 € | 1 month |
|-------------------------------------|-------|---------|

VIDEO FORMATS

| | | |
|--|-------|---------|
| Promotional pop up video It opens automatically at the first access to the site without a click by the user, followed by scrolling on the page (in browsers which support this function) and then it remains fixed in the right column as the first banner | 800 € | 1 month |
| Video interview with editor | 900 € | 30 days |
| Video interview with director (customized quotation) | | |
| Video advertorial in a highlighted box. It can be opened by a click | 850 € | 15 days |

MACPLAS ONLINE MOBILE VERSION

DIGITAL STANDARD FORMATS

| BANNER (MAX 100 KBYTE) | SIZE | EURO (VAT EXCL.) | LENGTH OF TIME |
|-------------------------|-----------------|------------------|----------------|
| Top header | 1,230x130 pixel | 200 € | 1 month |
| Side banner (all pages) | 390x149 pixel | 150 € | 1 month |

VIDEO

| | | | |
|-----------------------|---------------|-------|---------|
| Video standard banner | 390x149 pixel | 200 € | 1 month |
|-----------------------|---------------|-------|---------|

MACPLAS E-NEWS

DIGITAL STANDARD FORMATS

| BANNER (MAX 100 KBYTE) | DESCRIPTION | EURO (VAT EXCL.) | LENGTH OF TIME |
|---------------------------------------|-----------------|------------------|----------------|
| Top header (all pages) | 1,230x130 pixel | 800 € | 1 month |
| Central banner (after the first news) | 810x154 pixel | 750 € | 1 month |
| Side banner (on the right) | 390x149 pixel | 470 € | 1 month |

ADVERTORIAL

| | | | |
|-------------------------------|--|---------|---------------|
| Advertorial (first position) | text max 3,000 characters + 1-2 pictures (72 dpi, width max. 500 pixels) | 450 € | 1 newsletter |
| | | 1,200 € | 4 newsletters |
| Advertorial (second position) | testo max 3000 caratteri + 1-2 foto (72 dpi, width max. 500 pixel) | 300 € | 1 newsletter |
| | | 900 € | 4 newsletters |

VIDEO FORMATS

| | | |
|---|---------|---------------|
| Video Advertorial 1 st position (placed in a highlighted box, it can be opened by a click) | 550 € | 1 newsletter |
| Video Advertorial 1 st position (placed in a highlighted box, it can be opened by a click) | 1,300 € | 4 newsletters |
| Video Advertorial 2 nd position (placed in a highlighted box, it can be opened by a click) | 400 € | 1 newsletter |
| Video Advertorial 2 nd position (placed in a highlighted box, it can be opened by a click) | 1,100 € | 4 newsletters |

Newsletters will not be published on the occasion of Italian holidays: from August 1 until August 31 and from December 23 until January 6

Member discount
Amoplast
and Assogomma:
15%

Files can be saved in GIF or JPG

MACPLAS E-NEWS

The Italian newsletter **MacPlas E-News** contains a selection of the news published on www.macplas.it and it is mailed twice a week (on Monday and Thursday) to about 20,000 Italian addresses, whilst the English version is sent once a week (on Wednesday) to 30,000 foreign addresses.

Most of readers are plastics and rubber processors, but also machinery manufacturers, producers of raw materials, research institutes, agents etc... Rates and sizes of banner ads are the following:

2025 EDITORIAL PLAN

| MACPLAS ISSUE | MACHINES AND AUXILIARY EQUIPMENT | TRADE FAIRS | DEADLINE FOR EDITORIALS | DEADLINE FOR AD MATERIALS |
|---------------------------------|--|---|-------------------------|---------------------------|
| 404 January/February | Welding and printing Cylinders and screws Automation | Mecspe 5-7 March 2025 Bologna | 15/11/2024 | 02/12/2024 |
| 405 March/April | Hydraulic, hybrid, electric injection moulding machines Calenders and winders Vision and selection systems | SPS Italia 13-15 May 2025 Parma | 15/01/2025 | 30/01/2025 |
| 406 May/June | Blow moulding machines Thermoregulation and refrigeration IML and decoration | Greenplast 27-30 May 2025 Milan | 28/02/2025 | 24/03/2025 |
| 407 July/August | Extrusion lines Granulators and shredders Laser systems | | 15/05/2025 | 30/05/2025 |
| 408 September/October | Rotational moulding systems Hot runner systems Processing of foamed materials | Ecomondo Rimini November 2025 K 8-15 October 2025 Düsseldorf | 16/06/2025 | 30/06/2025 |
| 409 November/December | Thermoforming machines Mixing and dosing systems Additive manufacturing and 3D printing | | 15/09/2025 | 30/09/2025 |

| MACPLAS INTERNATIONAL | MACHINES AND AUXILIARY EQUIPMENT | TRADE FAIRS | DEADLINE FOR EDITORIALS | DEADLINE FOR AD MATERIALS |
|--|---|---------------------------------------|-------------------------|---------------------------|
| MacPlas International May 2025 (in English) | Recent innovations in processing technologies and auxiliary equipment with a particular focus on solutions presented at Greenplast 2025 | Greenplast 27-30 May 2025 Milan | 28/02/2025 | 24/03/2025 |
| MacPlas International October 2025 (in English) | Recent innovations in processing technologies and auxiliary equipment with a particular focus on solutions presented at Greenplast 2025 | K 8-15 October 2025 Düsseldorf | 15/06/2025 | 15/07/2025 |

Editorial topics, distribution trade shows and delivery dates of editorials and advertisements listed in this price list are indicative only and may change according to the needs of the editorial team. The delivery of editorials and advertisements is the responsibility of the companies. The editorial team cannot be held responsible for the failure to receive advertisements and editorials by the mentioned and/or contractual deadlines and reserves the right to assess the suitability for publication and to schedule the publication of editorials and advertisements received.

The magazines in Italian are published approximately between the last week of the first month and the first week of the second month of each issue's cover. The international editions are published in time for shipment to the relevant trade fairs according to the editorial plan.

THEY HAVE CHOSEN MACPLAS

ALFATEST • ALPHAMAC • AMAPLAST • AMUT • JOHNSON FLUITEN • KISTLER • KRAIBURG TPE •
ARBURG • BANDERA • BARUFFALDI PLASTIC MAAG • MACCHI • MAGIC MP • MAIN TECH •
TECHNOLOGY • BATTENFELD - CINCINNATI • MARIS • MAST • MAYR • MECCANOPLASTICA •
BAUSANO & FIGLI • BD PLAST FILTERING SYSTEMS • MERO • MITO POLIMERI • MIXACO •
BFM • BIESSE • BMB • BREAK MACHINERY • BRUKER MIXRON • MORETTO • MOVING • NEGRI BOSSI •
ITALIA • CALDARA PLAST • CAMPETELLA ROBOTIC OMSO • PET SOLUTIONS • PETCORE EUROPE •
CENTER • CHIMAR • CHINAPLAS • CMG PIOVAN • PLAS MEC • PLAST 2023 •
spa • CMS • COLINES • COMERIO PLASTICS RECYCLING SHOW
ERCOLE • COVESTRO • DGTS • **MACPLAS** EUROPE • PLASTORE • PRESMA •
DISTRUPOL • ECOMONDO •  PREVIERO • PROCHEMA •
ELESA • ENGEL • EREMA • PROFILE DIES • RADICIGROUP •
EUROMAP • EUROVITI • ROBOLINE • SARA • SBS •
EXACT • FAKUMA • FAP • FB SICA • SIKORA • SILICONE
BALZANELLI • FIMIC • FORMNEXT • EXPO EUROPE • SIRMAX • SITRA •
GAMMA MECCANICA • GAMMA STAMPI • GEFRAN • SK • SOREMA • SPS ITALIA • STAR AUTOMATION
GIBITRE INSTRUMENTS • GIMATIC • GIURGOLA EUROPE • TECNO SYSTEM • TECNOMATIC •
STAMPI • GRAFE • GREENPLAST 2025 • HELIOS TECNOVA • TRIA • ULTRA SYSTEM • UNION •
ITALQUARTZ • HERBOLD • HOLONIX • HS- UNITECHEM • VANETTI • VECOPLAN • WITTMANN
UMFORMTECHNIK • HUSKY • ICMA SAN GIORGIO • BATTENFELD ITALIA • WM THERMOFORMING •
IMG • INGLASS • IPM • ITIB MACHINERY • ZAMBELLO RIDUTTORI • ZEON EUROPE

STAFF

Managing director:
Mario Maggiani
m.maggiani@promaplast.org

Editor in chief:
Luca Mei
l.mei@macplas.it

Editorial staff:
Giampiero Zazzaro
g.zazzaro@macplas.it

Editorial assistant:
Alice Polimeno
segreteria@macplas.it

AGENTS FOR ADVERTISING

Roberta Pagan (ITALY)
Tel.: (+39) 02 82283747
Cell.: (+39) 393 6772295
r.pagan@macplas.it

Martina Lerner (EU sales office)
Tel.: (+49) 6226 971515
lerner-media@t-online.de

PUBLISHING HOUSE: PROMAPLAST SRL
Centro Direzionale Milanofiori - Palazzo F/3
20057 Assago (MI)
Tel.: (+39) 02 82283735
Fax: (+39) 02 57512490
macplas@macplas.it
www.macplas.it